



## **VOZROZHDENIE LLC**

OKPD 27.90.40.190

ТУ 27.90.40-001-33120038-2018

APPROVED BY

B3P.2499-00.00.000LU

## **GATE MODELK-17**

### **B3P.2499-00.00.000IM INSTALLATION MANUAL**

27 sheets

2020

## CONTENTS

<b>1</b>	<b>General Provisions</b> .....	<b>4</b>
<b>2</b>	<b>Safety precautions</b> .....	<b>5</b>
<b>3</b>	<b>Preparing the product for installation</b> .....	<b>6</b>
	3.1 Procedure for transporting the product to the installation site .....	6
	3.2 Rules for unpacking the product .....	6
	3.3 Rules for visual inspection of the product .....	6
	3.4 Product installation site requirements .....	7
<b>4</b>	<b>Product installation and dismantling</b> .....	<b>8</b>
	4.1 Equipment required .....	8
	4.2 Product installation .....	8
	4.3 Product dismantling .....	10
<b>5</b>	<b>Gate connection and setting</b> .....	<b>11</b>
	5.1 Gate connection diagram .....	11
	5.2 Setting of gate operations modes .....	12
	5.3 Power connection .....	15
	5.4 Control panel connection .....	16
	5.5 Access control and management system connection (optional).....	16
	5.6 Control panel connection to the ACS controller .....	19
<b>6</b>	<b>Comprehensive inspection</b> .....	<b>22</b>
	6.1 Visual inspection and verification of the product readiness for use .....	22
<b>7</b>	<b>Acceptance of the installed product</b> .....	<b>23</b>

This Installation Manual (IM) applies to Oxgard gate K-17 and its modifications (hereinafter referred to as the product).

IM defines rules and a procedure for installation and commissioning of the product.

Before installing the product, please read the Operation Manual B3P.2499-00.00.000 (OM) as well.

Due to constant work on improving the product, changes to its design may be made, which are not represented in this IM revision.

The following abbreviations are used in this document:

OM — Operation Manual;

IM — Installation Manual;

PSU - power supply unit;

## 1 GENERAL PROVISIONS

For general safety when assembling and installing the product, take into account all the recommendations and instructions contained herein.

Before starting installation work, completely de-energize the product.



**DO NOT:**

INSTALL THE POWER SUPPLY MODULE INSIDE THE PRODUCT BODY AS IT MAY RESULT IN ELECTRIC SHOCK TO PERSONS.

INSTALL PRODUCT NOT IN DRY AND HEATED ROOMS, EXCEPT FOR MODIFICATIONS WITH INDEX A.

APPLY PASTES AND LIQUIDS CHEMICALLY AGGRESSIVE TO MATERIALS OF THE HOUSING WHEN CLEANING THE PRODUCT.

## 2 SAFETY PRECAUTIONS

Installation should be carried out with observance of "Regulations for Operation of Consumer Electrical Installations" and "Safety regulations for Operation of Consumer Electrical Installations".

The product shall only be installed by qualified personnel trained in handling of electrical devices and instructed on safety precautions when handling the electrical installations with voltages of up to 1000V.



**ATTENTION:** FAILURE TO COMPLY WITH THE SAFETY REQUIREMENTS SPECIFIED IN THIS SECTION CAN RESULT IN DEATH AND DAMAGE TO HEALTH, COMPLETE OR PARTIAL LOSS OF PERFORMANCE OF THE PRODUCT AND/OR AUXILIARY EQUIPMENT.



**ATTENTION:** MANUFACTURER WAIVES ANY RESPONSIBILITY FOR DEATH AND DAMAGE TO HEALTH, COMPLETE OR PARTIAL LOSS OF PERFORMANCE OF THE PRODUCT AND/OR AUXILIARY EQUIPMENT IF USER FAILS TO COMPLY WITH THE SAFETY REQUIREMENTS SPECIFIED IN THIS SECTION, AND ALSO VOIDS THE PRODUCT WARRANTY.

### **3 PREPARING THE PRODUCT FOR INSTALLATION**

#### **3.1 Procedure for transporting the product to the installation site**

The product in the original package can be transported without range limitation by air, closed road and rail transport provided it is protected against direct exposure to precipitation and dust.

In order to avoid condensation of moisture after transportation at subzero temperatures, the product shall be held in a room with normal climatic conditions for 12 hours.

Loading and unloading operations should be carried out in compliance with safety regulations.

#### **3.2 Rules for unpacking the product**

3.2.1 Perform visual inspection of the packaging. There shall not be visible damage on the package.

3.2.2 Open the transportation box, unpack and check completeness of the product:

#### **3.3 Rules for visual inspection of the product**

3.3.1 Check completeness of the product.

Completeness shall be checked according to the Logbook B3P.2499-00.00.000 (LB).

3.3.2 Visually inspect the product. There shall not be visible damage on the product.

3.3.3 If any damage is found, prepare a Claim Report.

3.3.4 Figure 1 – overall product dimensions

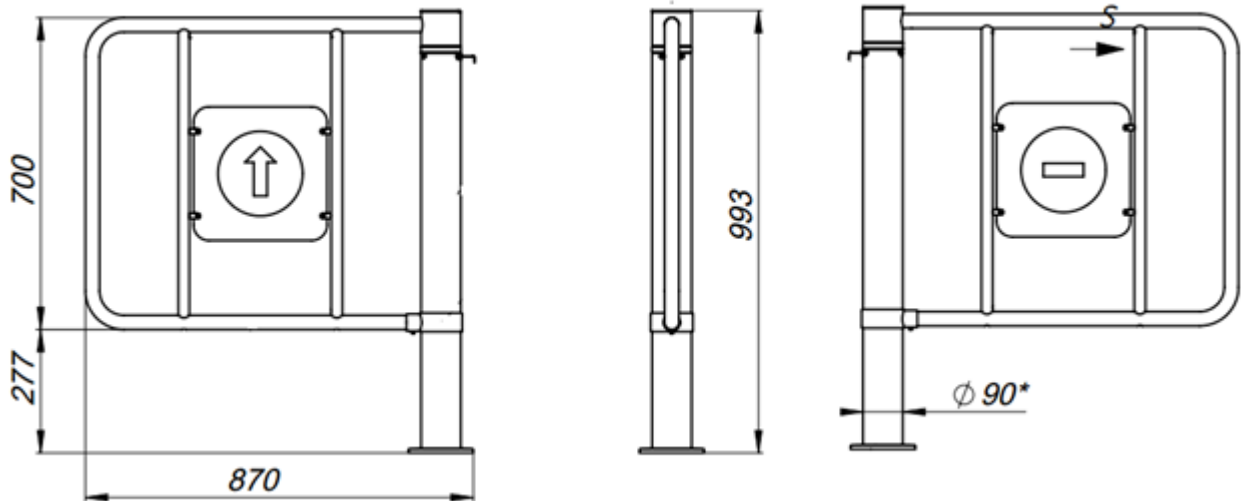

Figure 1 – overall product dimensions

### 3.4 Product installation site requirements



**ATTENTION:** TO AVOID SWING AND/OR OVERTURN DURING OPERATION, INSTALL THE PRODUCT SECURELY. IN CASE OF PRODUCT INSTALLATION ON LOW STRENGTH FLOOR, TAKE MEASURES FOR INSTALLATION SITE FLOOR STRENGTHENING.

## 4 PRODUCT INSTALLATION AND DISMANTLING

### 4.1 Equipment required

Equipment required for the product installation:

- 1) electric perforating machine
- 2) 16 mm carbide drill bit for drilling anchor holes in the floor (we recommend SORMAT PFGES10 M10-60 anchor);
- 3) S6 hollow head screw hex wrench;
- 4) cross-point screwdriver;
- 5) plumb or level;
- 6) steel shims for product leveling;

### 4.2 Product installation



**ATTENTION:** THOROUGHLY READ THIS SECTION OF THE MANUAL BEFORE INSTALLING THE PRODUCT



**ATTENTION:** IT IS RECOMMENDED TO MARK OUT LOCATING HOLES AGAINST HOLES IN GATE POST BASE FLANGE WITH MOUNTED FLAP.

4.2.1 Prepare a level ground at the product installation site.

4.2.2 Prepare cable trench or duct from site to the BP and control buttons installation site.

4.2.3 Attach gate flap to post using set screws. Make sure that gate flap is securely attached to post.

4.2.4 Figure 2 – mark out and drill 3 holes of 16mm in diameter in the floor for the gate post anchors.



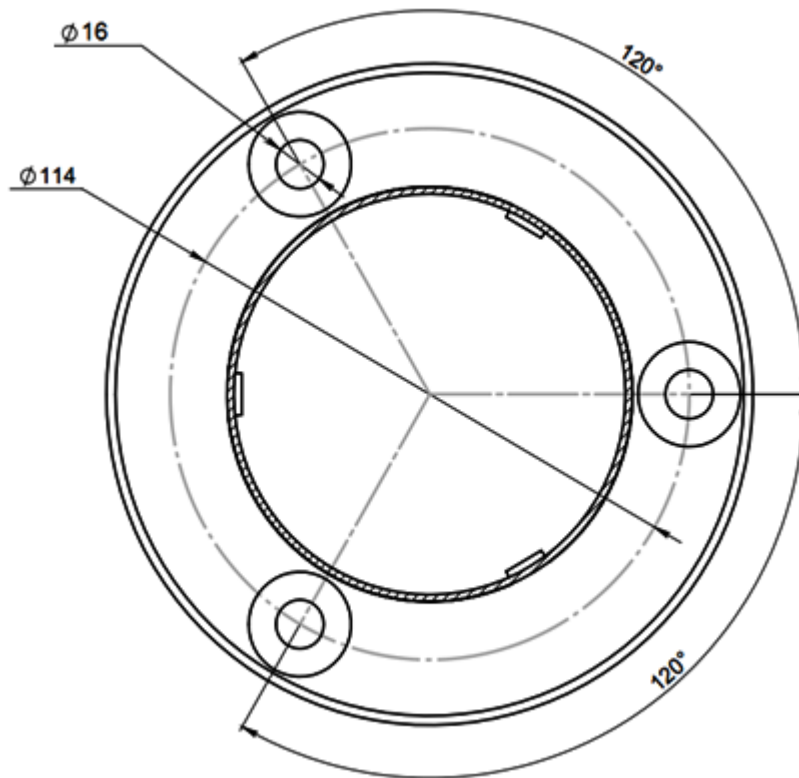

Figure 2 – Installation site mounting dimensions

The depth of holes for embedded parts shall exceed the anchor length by 5mm.

Insert anchors into the holes.

4.2.5 Lay PSU and control buttons cables into the cable duct or trench.

4.2.6 Install the gate post to the prepared site.

4.2.7 Align the gate post holes with the floor anchors.

4.2.8 Check that installed gate is vertical in 2 planes, use steel shims of required thickness for the correct gate installation, where necessary.

4.2.9 Fasten gate base flange with three screws M10 by screwing these into the proper anchors using the S6 wrench.

4.2.10 Lead cables from PSU, ACS and control panel into the product housing. Secure the cables with cable ties.

### **4.3 Product dismantling**

4.3.1 When sending the product for calibration or repair, dismantle product as follows:

- 1) turn product power off;
- 2) disconnect the product from the power supply source;
- 3) disconnect the product cable part from auxiliary cables;
- 4) remove the product from the installation site.

4.3.2 Before packing, clean the product from dust and dirt.

4.3.3 Put the product in a packing box.

## 5 GATE CONNECTION AND SETTING

### 5.1 Gate connection diagram

Figure 3 – gate diagram and diagram of PSU and control panel connection to gate control board.

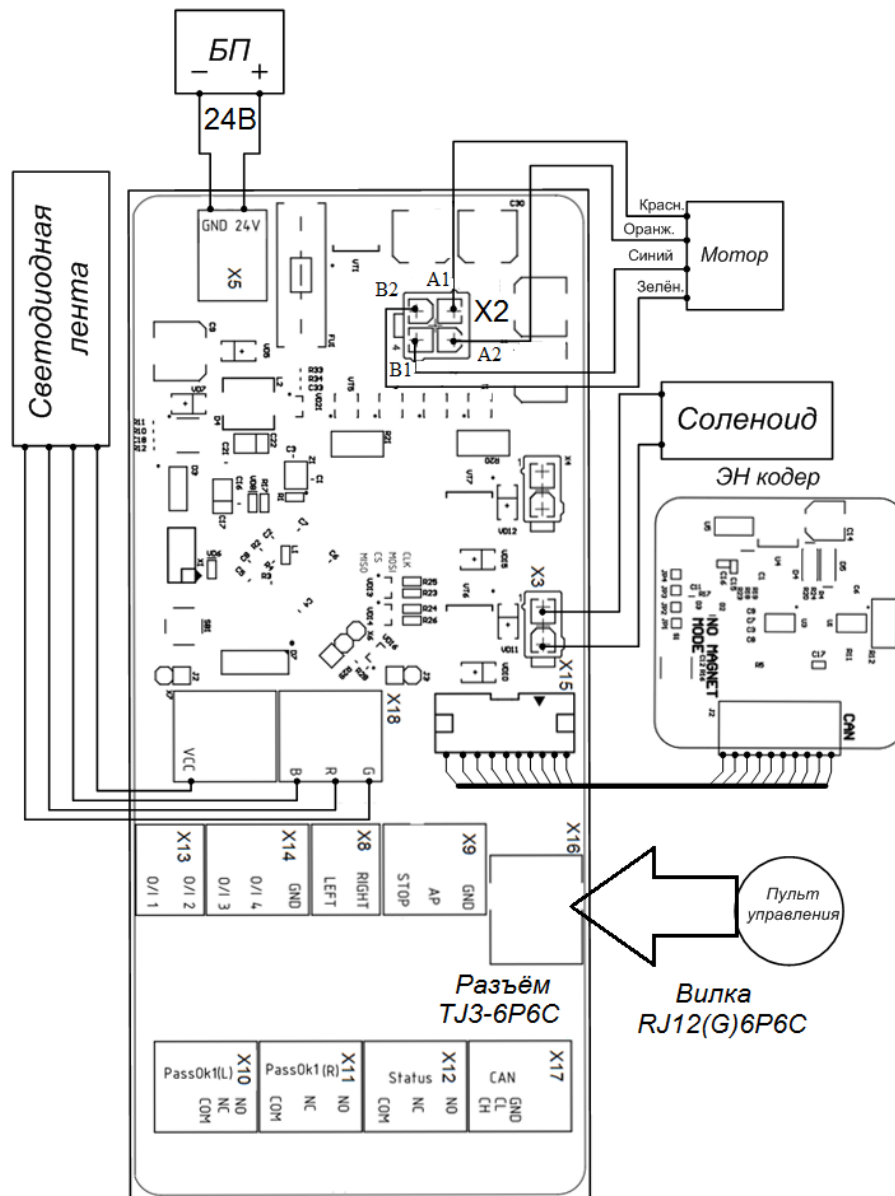

*LED strip / Motor/ Red / Orange / Blue / Green / Solenoid / Encoder / Control panel / Socket / Plug*

Figure 3 – Gate connection diagram

Figure 4 – the gate control board appearance and layout of the connectors for connecting the PSU, CP, ACS and SFAS are shown.

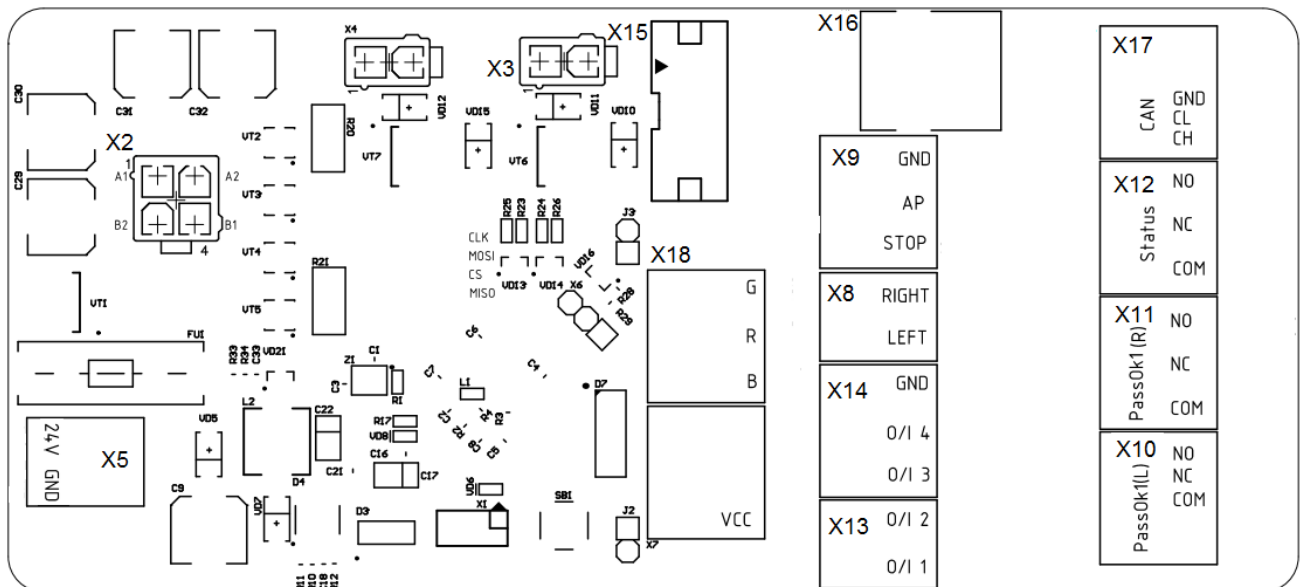

Figure 4 – Gate control board appearance

For power connection, use the double-wire cable ShVVP 2×1.5 up to 10m, and for ACS connection, use the eight-wire signal cable.

## 5.2 Setting of gate operations modes

To access the setting mode:

1. Switch to “STOP” or “ANTI-PANIC” mode.
2. Press and hold “LEFT” and “ANTI-PANIC” buttons for 5 seconds.
3. All LEDs will be off.
4. Within 3 seconds, press and release “STOP” button while holding “LEFT” and “ANTI-PANIC” buttons.
5. Then:
  - when gate is in the pulse mode, blue indicator lights up, and while in potential mode, white indicator lights up;
  - “ANTI-PANIC” LED is flashing, when gate switches to “ANTI-PANIC” mode with corresponding ACS contacts closed, or “ANTI-PANIC” and ”STOP” LEDs are

flashing, when gate switches to “ANTI-PANIC” mode with corresponding ACS contacts broken.

6. Thereupon, release the other buttons.

7. Now gate is in programming mode; you may choose and write the required operation mode.

#### **4 gate setting modes are available from panel:**

1. Gate operation control mode selection (pulse or potential);
2. “ANTI-PANIC” mode opening direction selection;
3. Panel on/off selection;
4. Selection of mode of switching to «ANTI-PANIC” mode with ACS contacts closed or broken.
5. Reset to factory settings.

#### **1. Gate operation control mode selection (pulse or potential).**

- In the programming mode, white indicator lights when gate is in the potential mode or blue indicator lights while in the pulse mode.

#### ***To change the operation mode:***

- **Press and hold “STOP” button** for 5 seconds until gate LED strip changes from white to blue (switching to pulse mode) or from blue to white (switching to potential mode).

- Thereupon, release “STOP” button.

- To store settings in memory, press and hold “STOP” button once again for 5 seconds until gate calibration starts. During calibration, all CP buttons are flashing, and gate swings to the fully open position, stops and then returns to initial position.

- After this, gate is restarted; it switches to the calibration mode, and indicators light up blue (pulse mode) or white (potential mode).

## 2. “ANTI-PANIC” mode opening direction selection.

- switch the gate to programming mode.

*To change direction:*

- **Press and hold “LEFT” button.** After the “LEFT” button is held for 5 seconds, “LEFT” and “RIGHT” LEDs light up.

- The “ANTI-PANIC” mode opening direction changes to opposite one.

- Then release “LEFT” button.

- To store settings in memory, press and hold “LEFT” button once again for 5 seconds until gate calibration starts. During calibration, all CP buttons are flashing, and gate swings to the fully open position, stops and then returns to initial position.

After this, gate is restarted; it switches to the calibration mode, and indicators light up blue while in pulse mode and white while in potential mode.

## 3. Panel on/off selection.

- switch the gate to programming mode.

*To switch panel off:*

- **Press and hold “RIGHT” button.** After the button is held for 5 seconds. When gate control commands were sent from panel, it switches off, and otherwise, if panel was off, gate panel control command issue function is enabled.

- To store settings in memory, press and hold “RIGHT” button once again for 5 seconds until gate calibration starts. During calibration, all CP buttons are flashing, and gate swings to the fully open position, stops and then returns to initial position.

After this, gate is restarted; it switches to the calibration mode, and indicators light up blue while in pulse mode and white while in potential mode.

## 4. Selection of mode of switching to «ANTI-PANIC” mode with ACS contacts closed or broken.

- switch the gate to programming mode.

- in the programming mode, “ANTI-PANIC” LED is flashing, when gate switches to “ANTI-PANIC” mode with corresponding ACS contacts closed, or “ANTI-PANIC” and “STOP” LEDs are flashing, when gate switches to “ANTI-PANIC” mode with corresponding ACS contacts broken.

*To change mode*

- **Press and hold “ANTI-PANIC” button.** After the “ANTI-PANIC” button is held for 5 seconds, only “ANTI-PANIC” LED lights up, and gate switches to “ANTI-PANIC” with closed ACS contacts, otherwise, “ANTI-PANIC” and “STOP” LEDs light up, and gate switches to “ANTI-PANIC” with broken ACS contacts.

- Then release “ANTI-PANIC” button.

- To store settings in memory, press and hold “ANTI-PANIC” button once again for 5 seconds until gate calibration starts. During calibration, all CP buttons are flashing, and gate swings to the fully open position, stops and then returns to initial position.

After this, gate is restarted; it switches to the calibration mode, and indicators light up blue while in pulse mode and white while in potential mode.

### 5. Reset to factory settings.

- To reset to factory settings, switch the gate to the programming mode.

- While in programming mode, press and hold “LEFT” and “ANTI-PANIC” buttons for 3 seconds until the gate is restarted. After the restart and calibration, gate is reset to following factory settings:

- pulse control mode
- panel is on for controlling the gate
- gate switches to the “ANTI-PANIC” at making the “AP” and “GND” contacts.
- “ANTI-PANIC” mode opening direction is leftward.

### 5.3 Power connection



**DO NOT:**

USE THE POWER SUPPLY UNITS WITH AN OUTPUT CURRENT BELOW 5A.

PRODUCT POWER CONNECTION USING THE CABLE WITH CROSS-SECTION LESS THAN 1.5MM<sup>2</sup> IS PROHIBITED. WHEN POWER CABLE LENGTH EXCEEDS 10M, IT IS RECOMMENDED TO USE CABLE WITH CROSS-SECTION OF 2.5MM<sup>2</sup>.



**ATTENTION:** IT IS NOT RECOMMENDED TO USE PULSE POWER SUPPLY UNITS AND TO INSTALL POWER SUPPLY UNITS MORE THAN 25M APART FROM PRODUCT.

The gate is powered by 24VDC power supply. Maximum current consumption – 4A. PSU should be selected based on these parameters.

It should also be taken into account that voltage drop increases with increase in supply cable length (for operating voltage range, see OM).

Install the PSU in location ensuring easy operator access. Figure 3 – Connect in accordance with diagram. Make sure that the cable is securely connected.

#### 5.4 Control panel connection

CP is connected through the telephone socket H16 on the gate control board TJ3-6P6C using the telephone connector RJ12(G)\6P6C.



TJ3-6\6P6C



RJ 12(G)\6P6C

#### 5.5 Access control and management system connection (optional)

The ACS controller shall be connected to the gate control contact group



Identification of contacts: LEFT, RIGHT, STOP, AP, GND. The contact assignment is shown in Table 2.

Table 1 – ACS contact assignment

Identification of contacts	Contact assignment
LEFT, RIGHT	one-time passage left/ right (lower priority)
STOP	passage forbidden ("Stop" mode) (medium priority)
GND	common contact
AP	free passage in both directions ("Antipanic") (highest priority)

Inputs for ACS connection differ in priority:

- 1) AP input has the highest priority. If the AP command was sent to this input (AP is closed to the GND contact), the gate is in free passage mode and **DOES NOT RESPOND(!)** to any commands as long as AP is closed to the GND contact; green LEDs are flashing on the indication panel. AP command can only be cancelled by breaking the AP from GND.
- 2) In order to enable "ANTI-PANIC" mode, close or break AP to GND contact. 4 modes (see p. 5.2 of this manual) are available through setting
- 3) LEFT and RIGHT have the same low priority and enable one-time passage in either direction. When both inputs are closed, passage is permitted in direction, of which input was closed first. In case that no passages are performed, gate switches to the "STOP" mode automatically in 7 seconds.



**ATTENTION:** WHEN THE AP INPUT IS CLOSED TO GND, PANEL COMMANDS ARE IGNORED, SINCE THE ACS HAS A HIGHER PRIORITY.

LEFT and RIGHT inputs can operate in both potential and pulse modes (tripping in respond to closing to GND contact). Pulse mode is set by default.

To switch to the potential operation mode, follow the operation mode selection instructions in p. 5.2. In this case, left/right passage mode is only enabled as long as the control signal is delivered to LEFT/RIGHT inputs.

Control board is equipped with two "dry contact" relay outputs for the ACS: PassOk1(R) - to the right, and PassOk1(L) - to the left.

NO and COMM – fail safety connection, NC and COMM – fail secure connection.

Tripping of one of contacts groups indicates the gate closing, PassOk1(R) – to the right, PassOk1(L) – to the left. "Dry contact" makes/breaks at the start of gate flap closing.

Control board is equipped with the AP "dry contact" relay output for the ACS. Its contacts (NC, NO and COM) make or break when gate switches to the "AP" mode, and VD24 LED lights up .

**Ошибка! Источник ссылки не найден.** Some LEDs are installed on control board to check its operation.

- 1) D23 indicates passage to the right and relay trip (PassOk1 - to the right).
- 2) D22 indicates passage to the left and relay trip (PassOk2 - to the left).
- 3) D24 is either constantly on indicating the "AP" command activation (in hold mode).

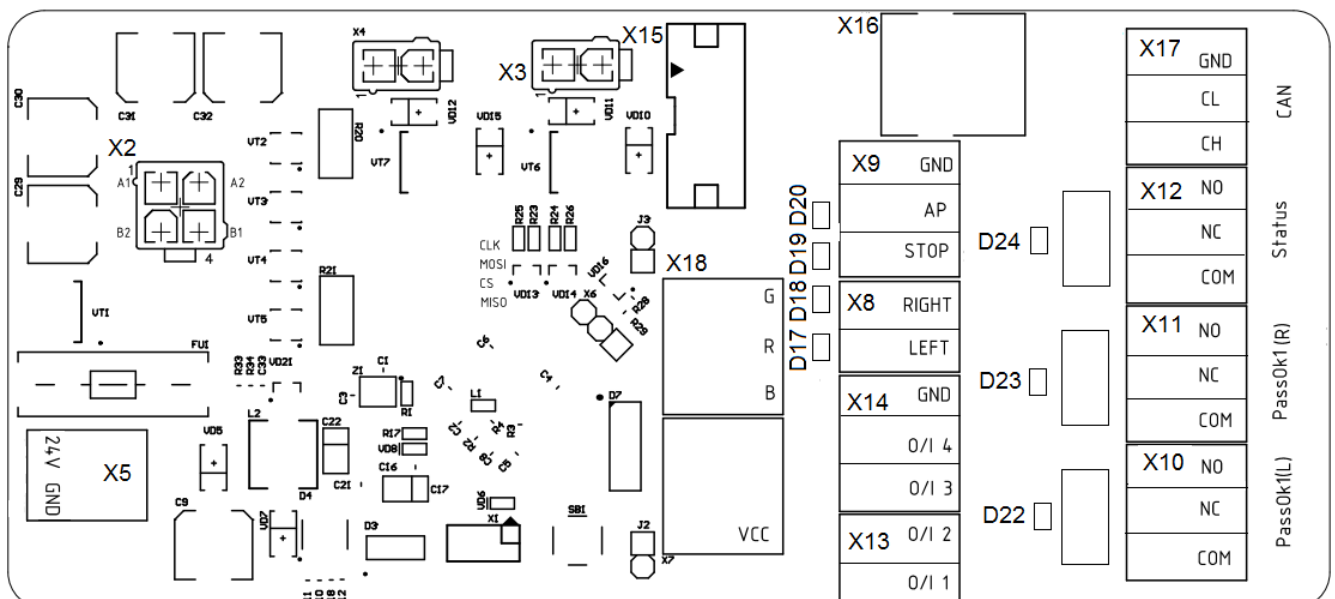

Figure 5 – Gate control board.

**Ошибка! Источник ссылки не найден.**For connecting to ACS, wires connected to gate control board are used, which are led out of gate housing as various color harnesses:

- 1) Green harness is connected to the gate input signal group: LEFT - white, RIGHT - green, STOP - blue, AP - red; black - GND.
- 2) Blue harness is connected to the output signal group indicating the passages through the gate: PassOk1(R) COM – blue, NO - yellow, PassOk1(L) COM – black, NO - red.
- 3) Yellow harness is connected to the output signals group: IO1 - yellow, IO2 - black, IO3 - blue, IO4 - red.
- 4) Connector H16 for gate panel connection is led out of the gate housing with RJ12 plug (G).
- 5) Connector X5 for 24V power connection is led out of the gate housing by the red harness with wire cross-section of 2×0.75. Brown +24V, blue GND

## 5.6 Control panel connection to the ACS controller

In some cases, the gate CP is be connected directly to the ACS controller, since the system recognizes passages permitted from the control panel (without using the controller) as "forced entry".

The use of this gate connection layout requires switching the control board to the panel control off mode (see p. 5.2). With such setting, gate does not respond to the control panel commands and just transmits their status to the IO1, IO2, IO3, IO4 contacts of control board terminal blocks. (LEFT, RIGHT, STOP, AP) being uncommitted collector outputs.

The contact assignment is shown in Table 2,

Figure 6 –Numbering of the CP buttons For this group of contacts, maximum output current shall not exceed 150mA, and permissible voltage shall not exceed 24V.

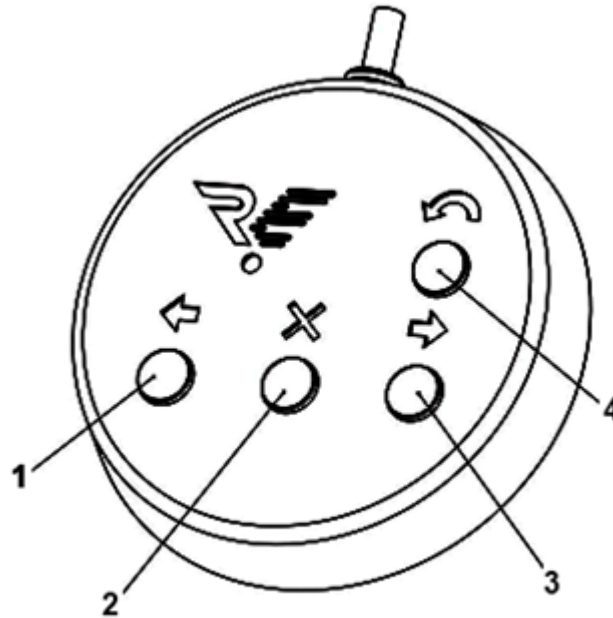

1, 2, 3, 4 - кнопки управления

**Control buttons**

Figure 6 – Numbering of the CP buttons

Table 2 – ACCES OUT contact group assignment

Identification of contacts	Contact assignment
LEFT	"LEFT" button (1) status
RIGHT	"RIGHT" button (3) status
STOP	"STOP" button (2) status
AP	"AP" button (4) status

LEFT, RIGHT, STOP and AP outputs represent current status of the CP buttons – the transistor opens when corresponding button is pressed.

LEFT, RIGHT, STOP and AP outputs can be connected either directly to the ACS controller or via a relay. Figure 7 – When using the relay, it is **MANDATORY(!)** to connect a diode in parallel to the winding.

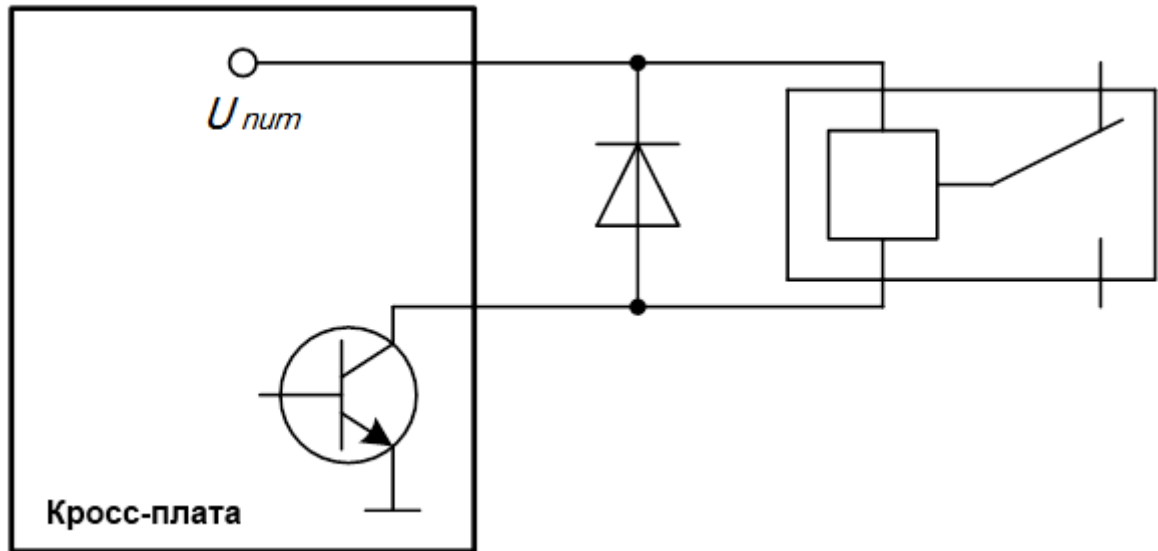

$U$  power

Cross-board

Figure 7 – Diagram for connecting a diode in parallel to the relay winding

## 6 COMPREHENSIVE INSPECTION

### 6.1 Visual inspection and verification of the product readiness for use

6.1.1 Check the fastening of product parts and components.

6.1.2 Check that all cables are securely attached.

6.1.3 Turn the product on and perform functional check by carrying out several test passes.

6.1.4 If no any abnormal noises and operational disturbances are detected, the product is ready for operation.

## 7 ACCEPTANCE OF THE INSTALLED PRODUCT

Acceptance of the installed product is carried out as follows:

- 1) representative of installation contractor demonstrates security of product installation;
- 2) notes on the product installation are made in the "Product Service Record" Section of the Logbook B3P.2499-00.00.000 (LB);
- 3) the "Installation Information" Section of the product Logbook B3P.2499-00.00.000 (LB) is filled in;
- 4) the Commissioning Certificate is issued.









Vozrozhdenie LLC

192289 Saint-Petersburg

66, Sofiiskaya str.

Telephone/Fax +7 (812) 366 15 94

[www.oxgard.com](http://www.oxgard.com)

[info@oxgard.com](mailto:info@oxgard.com)

