

CHECKOUT GATES

Universal barrier checkout gate SW 023.000

The gate is mounted on pipes that connect the posts of the lower barriers. Used for controlling the movement of clients in the checkout area. The gate can open in two directions, left or right. Opening direction can be changed at user site by changing the socket of the bumper – M10 bolt (sruba imbusowa). The gate is not self re-tracking and is locked by a patented locker. It is made of steel coated with nickel chromium. To be used in closed places. Weight – 10 kg.

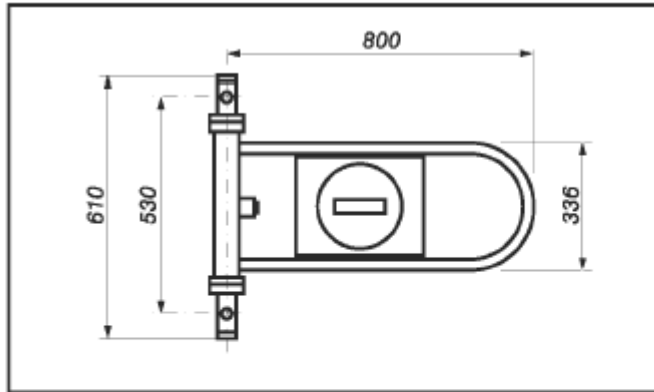

Universal stand-alone checkout gates SW 024.000

It is designed to work with checkout posts. The gate can open in two directions, left or right. Opening direction can be changed at site by changing the socket of the bumper – M10 bolt. The gate is not self re-tracking and is locked by a patented locker. It is made of steel coated with nickel chromium. To be used in closed places. Weight – 12 kg.

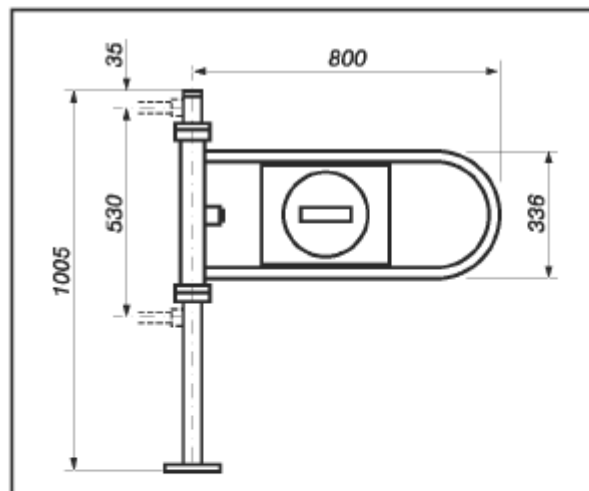

SW 024.000



SW 024.004



SW 024.001



SW 024.005



SW 024.002



SW 024.006



SW 024.003



SW 024.007



Universal checkout post gates SW 025.000

It possesses sliding wing ranging from 560mm – 1050mm. Works in two directions; by lifting up the wing, turning it 90 degrees left or right and then lowering it down. The gate is mounted to the checkout post with four Ø8 screws. The gate is made of steel coated with nickel chromium. To be used in closed places. Weight – 2.5 kg.

