

# Speedgate BS-DS2000

Last update: Apr. 2023

## User Manual



Please read and follow the installation instructions before operating the equipment, and keep the instructions for future reference or use after debugging.

# Contents

<b>1. Product Introduction.....</b>	<b>3</b>
1.1 Note.....	3
<b>2. Product Structure and Working Principle.....</b>	<b>3</b>
2.1 Electronic control system of channel gate.....	3
2.2 Operating principle of the system.....	4
<b>3. Install Instruction.....</b>	<b>5</b>
3.1 Installation note & suggestion.....	5
3.2 Turnstile circuit board wiring diagram.....	6
<b>4. Turnstile Circuit Board Description.....</b>	<b>7</b>
4.1 Gate Position Adjustment.....	7
A. Adjustment method for Swing Gate Mode.....	7
B. Adjustment method for Flap Gate Mode.....	7
4.2 Parameter Setting.....	7/8/9/10
<b>5. Product Maintenance.....</b>	<b>11</b>
5.1 Daily maintenance.....	11
5.2 Tips and troubleshooting.....	11
<b>6. Customer Services.....</b>	<b>11</b>

# 1. Product Instruction

## 1.1 Note

- 1) Before installation, operation or maintenance, turn off power.
- 2) Do not change the inside wiring, take a photo before any disconnection.
- 3) Do not use the turnstile inside power supply to connect other third-party device.
- 4) Do not operate when thundering and lightning, in case damage the turnstile electrical parts.

# 2. Product Structure and Working Principle

## 2.1. Electronic control system of channel gate

The electronic control system consists of card reader, main control board, infrared sensor, direction indicator board, alarm, transformer, etc.

**Card reader (self-provided):** after reading the information on the card and judging and processing, send the application pass signal (switch signal) to the main control board.

**Master control board:** the control center of the system, which receives signals from the card reader and infrared sensor, makes logical judgment and processing of these signals, and then issues execution commands to the direction indicator, motor, counter and alarm.

**Infrared sensor:** detect the pedestrian position and play the role of safety protection.

**Direction indicator light:** displays the current status of the channel and guides pedestrians to pass through the channel in a safe and orderly manner.

**Alarm:** when the system detects pedestrians entering the passage illegally, it will send out an alarm

Item NO.	NAME	FUNCTION
1	Entrance guard system	IC/ID card access control, fingerprint machine, face recognition, two-dimensional code device, gate opening signal on the control board of gate machine, remote control, button to open the gate(optional)
2	Control board	The control center of the system, which receives signals from the card reader and infrared sensor, and makes logical judgment and processing of these signals, and then sends out execution commands to the direction indicator, motor, counter and alarm.
3	Infrared sensor	Detect the position of pedestrians and safety protection
4	Direction indicator	Display the current traffic sign status of the gate and guide pedestrians through the gate
5	Alarm (speaker)	When the system detects a pedestrian illegally entering the passageway, it gives an alarm.
6	Motor	Drive the mechanism
7	Power Supply Switch	Control panel power supply

## 2.2. Operating principle of the system

- a) Turn on the power and the system will enter into working state after 3 seconds.
- b) When the card reader reads the valid card, the peak-mincer will make a pleasant sound, indicating to pedestrians that the card has been read successfully. At the same time, it will judge and process the information read from the card, and send an application for approval signal to the main control board.
- c) The main control board receives the signals from the card reader and infrared sensor, and after comprehensive processing, sends effective control signals to the direction indicator and motor, so that the direction indicator sign turns into the green arrow pass sign. At the same time, the turnstile sends the setting voice, the main control board controls the motor operation, and the gate is opened to allow pedestrians to pass.
- d) After the pedestrian passes through the channel according to the direction indicator, the infrared sensor senses the whole process of the pedestrian passing through the channel and continuously sends signals to the main control panel until the pedestrian has passed through the channel completely.
- e) If a pedestrian forgets to read his card or reads an invalid card and enters the channel, the system will forbid the pedestrian to pass through and issue a voice alarm. The alarm will not be lifted until the pedestrian exits the channel. Rereading a valid card allows passage.

## 3. Install Instruction

### 3.1 Installation note & suggestion

**Note:** During installation and construction, relevant circuits should be disconnected to ensure that all circuits are correct before energizing.

#### ►► Installation Suggestion:

- 1) For cables, suggest laid 60mm deep, over 50mm, and connector area be bending to avoid water.
- 2) If the turnstiles install in the outside, suggest installed in concrete deep 100-200mm to avoid natural damaged.
- 3) All the operation should be done when power off.
- 4) Wear the strong electric cable and the weak electric cable are respectively with 3/4 "PVC pipe and buried to the corresponding position with cement.
- 5) After adjusting the foundation surface, arrange the equipment in good order.
- 6) After the hole location is determined, drill the hole and embed the anchor bolt or expansion bolt of M12.
- 7) Open the case, select one of the equipment as the reference (preferably choose the middle one as the reference), align the base bolt hole with the corresponding anchor bolt, and pre-tighten the nut.
- 8) Connect the power line and control line according to the wiring diagram, and connect the system protection ground wire.
- 9) Check the mains wiring according to the wiring diagram, check the power wiring and other wiring of the whole equipment are correct, and the power can be adjusted after confirmation.
- 10) After completion of the installation, check the connection condition of earth wire, connector assembly for connecting line and all moving parts with the device. Make sure the connection is firm in order to prevent failure caused by long time operation. If any screw or part is not tightened, please tighten.
- 11) After the equipment status check is normal, the following functions can be debugged.

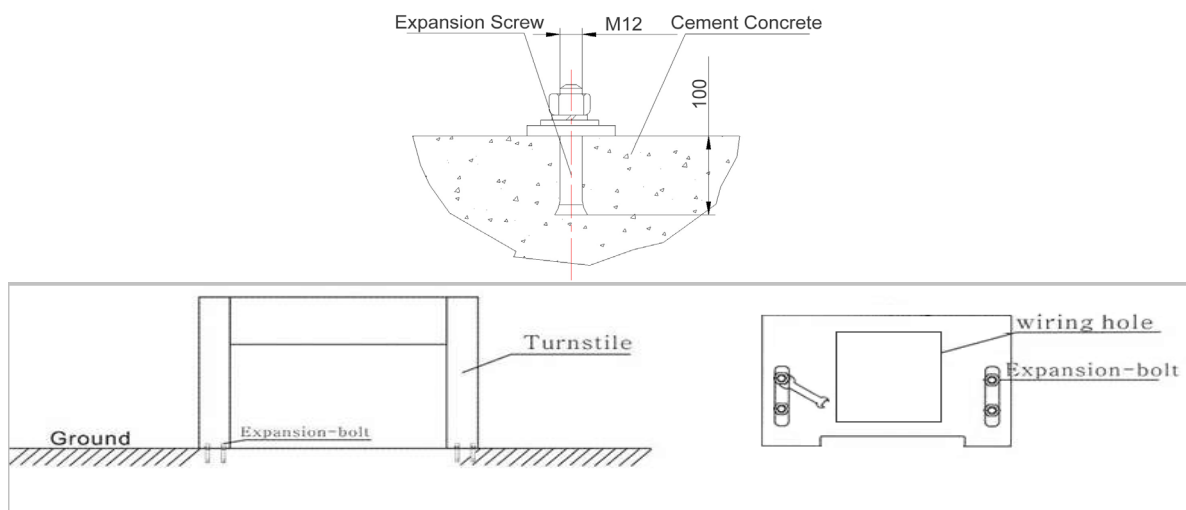

### 3.2 Turnstile circuit board wiring diagram

\*Turnstile electrical parts area with power supply port, please connect to 110V/220V electrical power supply.

\*Turnstile circuit board with port “OP-L”, “COM”, “OP-R”, it can be connected to any type of the third-party access controller device.

## Optical Turnstile Gate Wiring Diagram

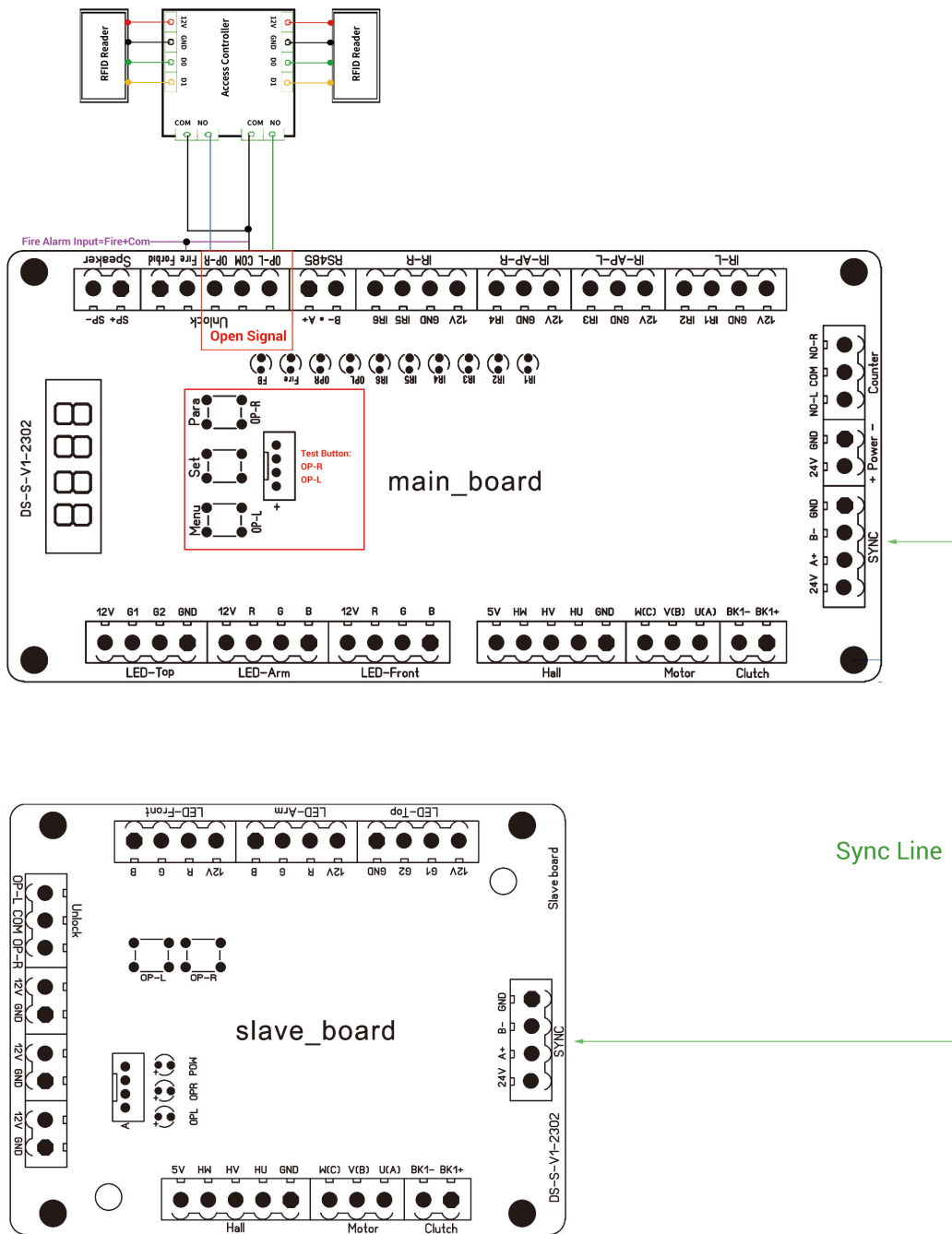

Sync Line

## 4. Turnstile Circuit Board Description

### 4.1 Gate Position Adjustment

#### Adjustment method for door panel position in Swing Gate Mode:

1. Press the SET button (middle button) 5 times in a row, and the system will prompt "Please manually adjust the position of the wing gate" and enter the wing gate (door panel) adjustment mode.

2. Push the door panel to the target position and stop, keep it still for 3 seconds, and the voice prompt "beep" or corresponding light flashing indicates that the current position has been sampled.

- The system will automatically determine whether the current sampling position is left in place, right in place or zero position based on the position of the wing gate.

3. Finally, push the door panel back to the center alignment and keep it still for about 10 seconds. The system will prompt "Setting completed, welcome to use" and exit the adjustment mode.

- In most cases, the system will automatically obtain appropriate left and right positions. Users only need to adjust the zero position, align the wing gate, and wait for the system to exit automatically.

#### Adjustment method for door panel position in Flap Gate Mode:

1. Press the SET button (middle button) 5 times in a row, and the system will prompt "Please manually adjust the position of the wing gate" and enter the wing gate (door panel) adjustment mode.

2. The "left open" and "right open" buttons on the main control board can control the main motor to move back and forth, and the "left open" and "right open" buttons on the sub-control board can control the sub-motor to move back and forth. Use the buttons to control the wing gate to move to the target position and stop, keep it still for 3 seconds, and the voice prompt "beep" or corresponding light flashing indicates that the current position has been sampled.

- The system will automatically determine whether the current sampling position is left in place or right in place based on the position of the wing gate.

3. Press and hold the middle button for more than 2 seconds and release it, and the program will exit the adjustment mode.

### 4.2 Parameter Setting

1. Press and hold the SET button (middle button) until the digital tube flashes to enter the parameter setting.

2. The first and second digits of the digital tube display the menu, and the third and fourth digits display the value. Press the left button to set the menu and the right button to set the value.

3. Press and hold for about 2 seconds, and the digital tube will stop flashing. The menu value is successfully saved.

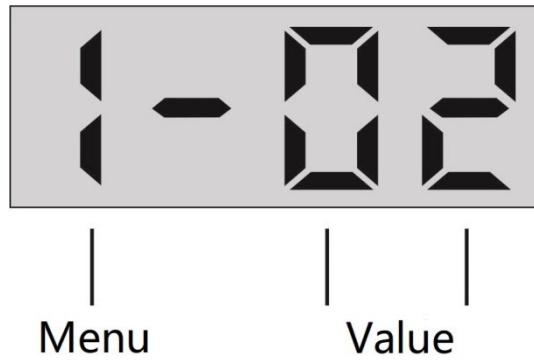

**Figure 5**

As shown in the figure, the current menu is "gate opening mode", and parameter 02 represents "left infrared free passage".

No.	Function	Range	Default	Details
0	Machine number	1~99	1	485 communication machine number
1	Gate opening mode	1~5	1	1: Standard mode. 2: Left infrared free passage. 3: Right infrared free passage. 4: Left and right infrared free passage. 5: Turnstile normally open. 6: Turnstile normally closed.
				During adjustment, the top light board will move accordingly, and the direction of infrared free passage can be referenced to the arrow direction.
2	Gate opening waiting time	1~90	8	Time unit: seconds. Press the plus button once for each parameter below 20, and press once for every 10 above 20.
3	Left gate opening voice prompt	0~9	0	0: Thank you; 1: Please pass; 2: Goodbye; 3: Welcome; 4: Welcome again; 5: Have a safe journey; 6: Have a pleasant trip; 7: Wear a safety helmet; 8: Verification successful; 9: Mute;
4	Right gate opening voice prompt	0~9	3	The direction of passage corresponding to the voice prompt can be referenced to the arrow direction on the top light board.
5	Voice volume	1~9	5	The higher the value, the louder the volume.
6	Main motor speed	1~25	13	When the combination gear ratio of the motor and the movement mechanism is too low, excessive speed may cause speed overload, and it needs to be adjusted according to the actual situation.
7	Slave motor speed	1~25	13	
8	Debug mode	0~2	0	1: Automatic aging mode. (Long press the middle button or power off and restart to release the mode)
				2: Restore factory settings. (Restart required to take effect)
9	Deceleration interval	1~30	10	The higher the value, the larger the deceleration interval, and the longer the distance of deceleration sliding.
				If the wing gate does not stop in place smoothly and crawls slowly, consider reducing the parameter;
				if the wing gate stops suddenly and shakes significantly, consider increasing the parameter.
10	Self-check running speed	1~9	3	The higher the value, the faster the self-checking speed.



11	Passing mode	0~2	0	0: Smooth passage mode, with a delay of 1 second to close the gate when an electric bicycle is detected.
				1: Open memory function, n people swiping card n people passing.
				2: One card per person mode, without electric bicycle detection function.
12	Close gate control	0~9	2	0: Close the gate after the pedestrian passes through the middle infrared. 1: Close the gate after the pedestrian triggers the last group of infrared.
				2: Close the gate after the pedestrian passes through the last group of infrared.
				3-9: Delay (n-2 seconds) to close after passing the last group of infrared
13	Single motor mode	0~1	0	0: Double motor mode (for two-way passage). 1: Single motor mode (for one-way passage).
14	Language selection	0~1	0	0: Chinese voice; 1: English voice.
15	Obstacle detection, infrared anti-pinch rebound	0~1	1	0: Obstacle detection without rebound. 1: Obstacle detection with rebound.
16	Mechanical anti-pinch sensitivity	1~9	5	The higher the value, the higher the sensitivity.
17	Reverse processing	0~1	1	0: Reverse trigger without closing the gate, only voice alarm.
				1: Reverse trigger to close the gate, this passage is invalid, and the gate will not open again.
18	Turnstile type	0~3	0	0: Standard swing gate (large swing gate, small swing gate, speed gate)
				1: Cylinder swing gate (supermarket swing gate) 2: Wing gate, 3: Swing gate one-way opening mode.
19	Power-off gate opening direction	0~2	2	0: Open the gate to the left after power failure.
				1: Open the gate to the right after power failure.
				2: The system automatically selects the power-off gate opening direction based on the current situation.
				The gate opening direction can be referenced to the arrow direction on the top light board.
20	Motor resistance	1~9	5	The higher the value, the greater the strength. Excessive strength may cause the power supply to restart. The 6.25A power supply is recommended to use the default value.
21	Illegal intrusion voice prompt	0~2	1	0: Turn off all alarm prompts.
				1: Prompt "Do not enter illegally" when an illegal intrusion event occurs.
				2: Prompt "Illegal intrusion, please swipe your face" when an illegal intrusion event occurs.
22	Left and right infrared effective signal delay	1~9	6	Time = parameter * 20 milliseconds (default 100ms)
23	Motor running direction	1~4	1	1: The main machine rotates forward, and the slave machine rotates backward; 2: The main machine rotates backward, and the slave machine rotates forward;

				3: The main machine and the slave machine rotate forward at the same time; 4: The main machine and the slave machine rotate backward at the same time;
24	Clutch constant locking function	0~3	0	0: Automatic detection of the clutch; 1: No clutch mode; 2: With clutch mode; 3: Clutch constant locking mode.
25	Motor Hall type	0~4	0	0: Automatic detection, 1: Main motor +120°, slave motor +120°, 2: Main motor -120°, slave motor -120°, 3: Main motor +120°, slave motor -120°,
26	Input signal filtering	1~9	3	Numeric value *10ms (default 30ms)
27	Anti-pinch priority setting	0~1	0	0: Fast passage mode, priority to open the gate, infrared anti-pinch is invalid during the gate opening process, and the gate can be opened when there is a signal from the left and right infrared; 1: Safe passage mode, priority to anti-pinch, infrared anti-pinch is valid during the gate opening process, and the gate cannot be opened when there is a signal from the left and right infrared.
28	Anti-tailgating alarm	0~2	0	0: Off; 1: Tailgating voice alarm, gate remains open; 2: Tailgating voice alarm and gate closes
29	Zero deviation alarm threshold	0~9	2	The larger the numeric value, the greater the deviation allowed by the door panel.
30	Anti-pinch infrared free passage switch	0~1	1	0: In free passage mode, the anti-pinch infrared does not trigger the gate to open; 1: In free passage mode, the anti-pinch infrared triggers the gate to open, facilitating fast passage.
31	Free passage memory function switch	0~1	1	0: In free passage mode, there is no memory function, and the infrared can only allow one person to pass through multiple triggers; 1: In free passage mode, the memory function is enabled, and the infrared can allow n people to pass through n triggers.
32	Main motor sliding compensation	0~9	0	If the switch gate panel cannot return to the zero position immediately after the self-check is completed, the sliding compensation can be increased appropriately.
33	Slave motor sliding compensation	0~9	0	
34	Number of infrared sensors	0~1	0	0: 4 pairs of infrared mode, the signal of either the left or right infrared AB circuit is valid 1: 6 pairs of infrared mode, both the left and right infrared AB circuits must have signals at the same time to be valid
35	Main machine welcome light mode	1~4	1	1: Linked with left opening, standby blue, left opening green, right opening red; 2: Linked with right opening, standby blue, left opening red, right opening green;
36	Slave machine welcome light mode	1~4	2	3: Constant green light, 4: Constant red light

## 5. Product Maintenance

### 5.1 Daily maintenance

- To avoid the risk of electric shock, always ensure the power off before inspecting.
- Suggest inspected at regular time, to ensure all parts in good working.
- The material made by stainless steel, do not use hard material to clean it.
- Fingerprints or stubborn stains cleaning way: scrub by soap water or alcohol, sponge rinse with clean water, wipe dry as necessary.

### 5.2 Tips and troubleshooting

1. After swiping card, if the arm doesn't open, please recheck whether all the wire well connected.
2. If indicator doesn't light, or indicate wrong direction, please exchange the inside wires to test.
3. Turnstile will automatically open after power off; if it did not, it caused by the storage battery power not enough. Make sure the storage batter with enough power.
4. The arm did not work together, check if the sync wires connect well.
- 5 .The arms open but fail to close, check infrared sensor if it matched well.

Digital tube cue	Fault	Reasons and solutions
E010	The main motor cannot be detected	The hall cable or motor cable is incorrectly connected, and the motor hall is faulty
E020	The slave motor cannot be detected	
E030	The main and slave motor cannot be detected	
E050	The self-check process is abnormal	Hall phase or motor phase sequence misconnection, motor failure, movement slip or stuck

## 6. Customer Service

We are very happy to help you in the future when you encounter problems or product defects, if the use or operation is not clear, please timely contact the after-sales service staff.