

Tripod BO-HVK3G501

Last update: Apr. 2023

User Manual



Please read and follow the installation instructions before operating the equipment, and keep the instructions for future reference or use after debugging.

Contents

| | |
|--|-----------|
| 1. Note..... | 3 |
| 1.1 Note..... | 3 |
| 2. Turnstile electric control system..... | 3 |
| 2.1 Turnstile electric control system..... | 3 |
| 3. Install Instruction..... | 4 |
| 3.1 Installation note & suggestion..... | 4 |
| 3.2 Turnstile circuit board wiring diagram..... | 5/6 |
| 4. Menu Parameter Setting..... | 6 |
| 4.1 Button introduction..... | 6/7 |
| 4.2 Menu setting..... | 7 |
| 4.3 Parameter setting instruction..... | 7/8 |
| 5. Product Maintenance..... | 9 |
| 5.1 Daily Maintenance..... | 9 |
| 5.2 Tips and Troubleshooting..... | 9 |
| 6. Customer Services..... | 10 |

1. Note

1.1 Note

- 1) Before installation, operation or maintenance, turn off power.
- 2) Do not change the inside wiring, take a photo before any disconnection.
- 3) Do not use the turnstile inside power supply to connect other third-party device.
- 4) Do not operate when thundering and lightning, in case damage the turnstile electrical parts.

2. Tripod turnstile electric control system

2.1. Tripod turnstile electric control system

The electronic control system is composed of card reader, main control board, direction indicator board, and transformer and so on...

- Card reader (self-provided): after reading the information on the card and judging and processing, it will send an application pass signal (switch signal) to the main control board.
- Main control board: the control center of the system, which receives the signals from the card reader, and makes logical judgment and processing of these signals, and then issues execution commands to the direction indicator light, motor, counter and alarm.
- Direction indicator light: display the current status of the passage signs and guide pedestrians to pass through the passage in a safe and orderly manner.

| Item NO. | NAME | FUNCTION |
|----------|------------------------|--|
| 1 | Entrance access system | IC/ID card access control, fingerprint machine, face recognition, two-dimensional code device, gate opening signal on the control board of gate machine, remote control, button to open the gate(optional) |
| 2 | Control board | The control center of the system, which receives signals from the card reader and infrared sensor, and makes logical judgment and processing of these signals, and then sends out execution commands to the direction indicator, motor, counter and alarm. |
| 3 | Direction indicator | The directional indicator light shows the current status of the passage sign and guides pedestrians through the passage |
| 4 | Limit switch | Check opening and closing position |
| 5 | Switch | Supply power to control board |

3. Install Instruction

3.1 Installation note & suggestion

Note: During installation and construction, relevant circuits should be disconnected to ensure that all circuits are correct before energizing.

►► Installation Suggestion:

- 5) For cables, suggest laid 60mm deep, over 50mm, and connector area be bending to avoid water.
- 6) If the turnstiles install in the outside, suggest installed in concrete deep 100-200mm to avoid natural damaged.
- 7) All the operation should be done when power off.
- 8) Wear the strong electric cable and the weak electric cable are respectively with 3/4 "PVC pipe and buried to the corresponding position with cement.
- 9) After adjusting the foundation surface, arrange the equipment in good order.
- 10) After the hole location is determined, drill the hole and embed the anchor bolt or expansion bolt of M12.
- 11) Open the case, select one of the equipment as the reference (preferably choose the middle one as the reference), align the base bolt hole with the corresponding anchor bolt, and pre-tighten the nut.
- 12) Connect the power line and control line according to the wiring diagram, and connect the system protection ground wire.
- 13) Check the mains wiring according to the wiring diagram, check the power wiring and other wiring of the whole equipment are correct, and the power can be adjusted after confirmation.
- 14) After completion of the installation, check the connection condition of earth wire, connector assembly for connecting line and all moving parts with the device. Make sure the connection is firm in order to prevent failure caused by long time operation. If any screw or part is not tightened, please tighten.
- 15) After the equipment status check is normal, the following functions can be debugged.

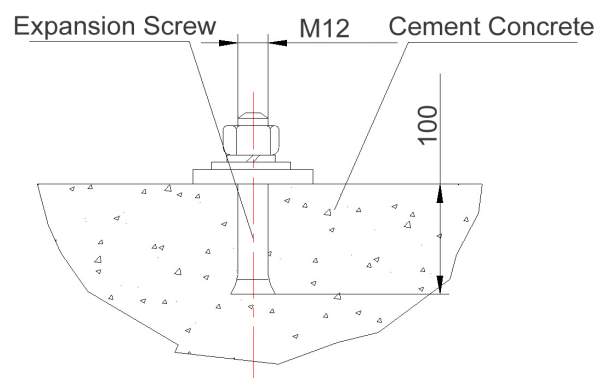

3.2 Turnstile circuit board wiring diagram

- *Turnstile electrical parts area with power supply port, please connect to 110V/220V electrical power supply.
- *Turnstile circuit board with port “OP-L,” COM”, “OP-R”, it can be connected to any type of the third-party access controller device.

Turnstile Wiring Diagram

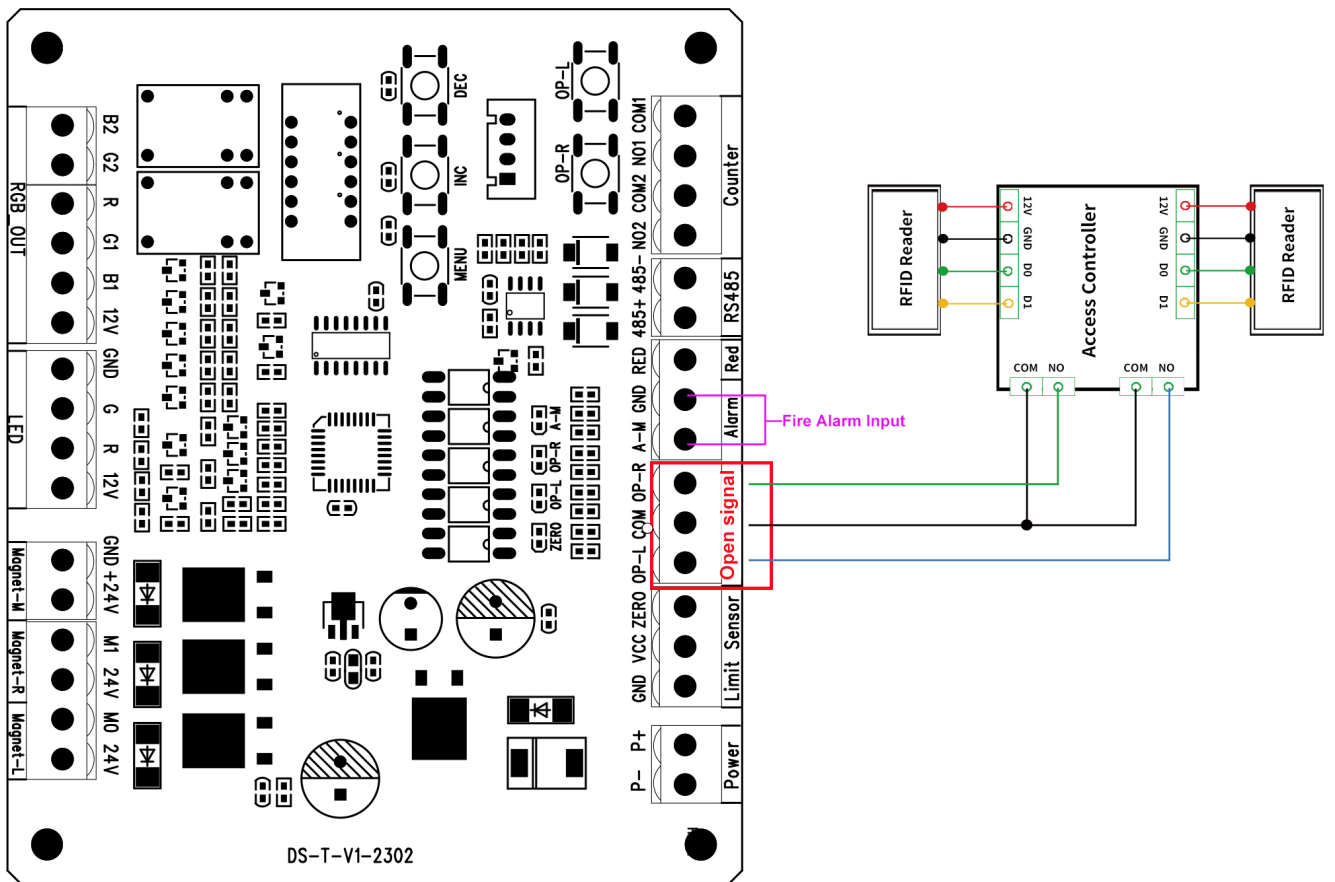

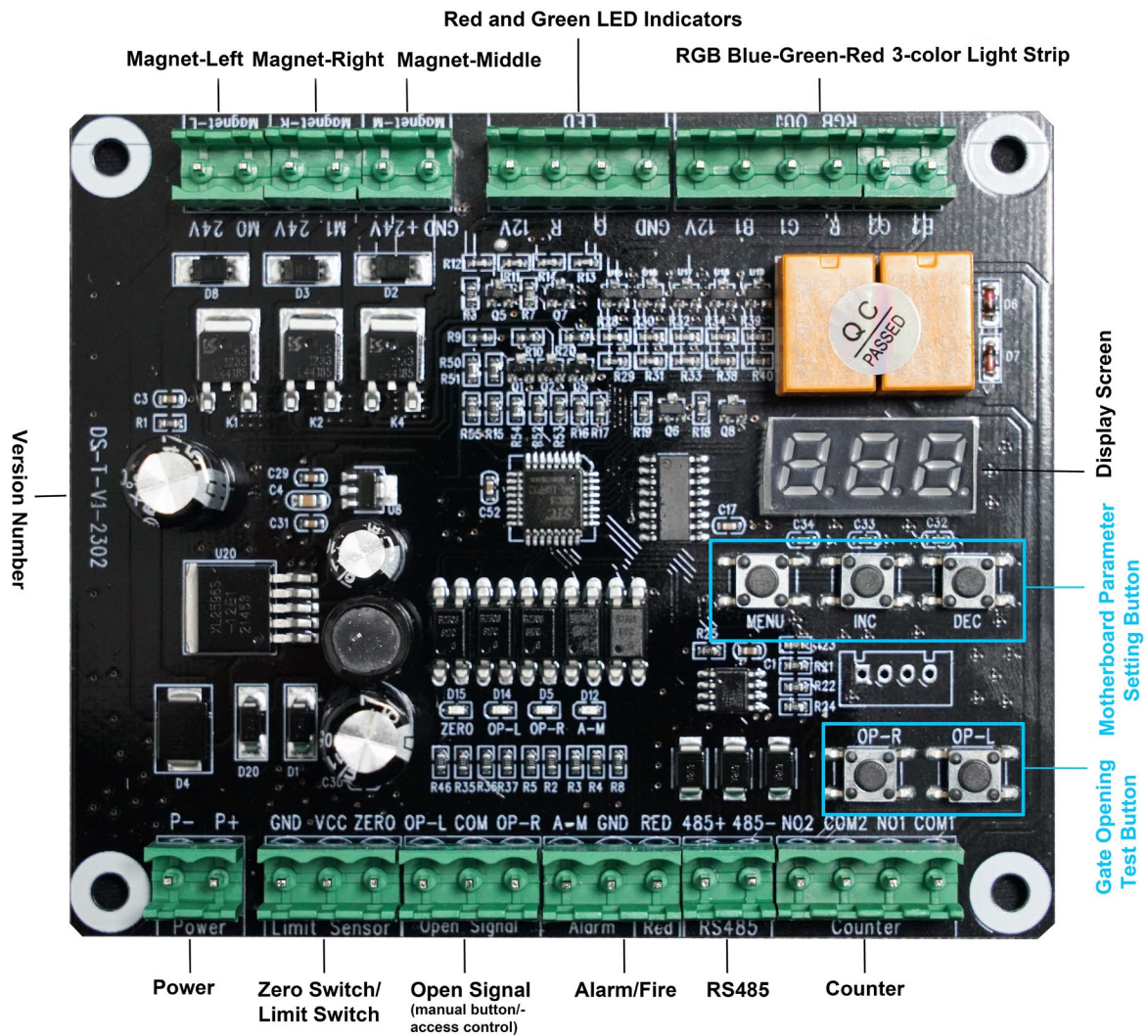

4. Menu Parameter Setting

4.1 Button introduction

Control board buttons: "**MENU**" menu key/confirm key, "**INC**" up/plus key, "**DEC**" down/minus key, three operation buttons.

Explanation of each function key:

"MENU" key:

1. It functions as the **menu key** on the standby interface, long press this key to enter the menu;
2. In the menu interface, it functions as the **confirmation key**, after selecting the corresponding menu, press this key to enter the menu parameter setting interface;
3. After the menu is set, press this key to save the parameters and return to the system menu interface.

"INC" key: It functions as the **+1 key** when scrolling up to select system menus and set parameters.

"DEC" key: It functions as the **-1 key** when scrolling down to select system menus and set parameters.

NOTE: In the system menu and menu setting interface, if there is no key operation within 5 seconds, the system will automatically exit the menu and return to the standby interface.

4.2. Menu setting

For example, to change the passage time of the gate to 3 seconds, follow these steps:

Step 1: Long press the **"MENU"** key to enter the system menu. Use the **"INC"** and **"DEC"** keys to scroll up and down and select the **"F 0 1"** menu (menu description below).

Step 2: Press the **"MENU"** key to enter the passage time setting interface.

Step 3: Use the **"INC"** and **"DEC"** keys to increase or decrease the parameter value and set it to number 3.

Step 4: After completing the setting, press the **"MENU"** key to save.

Step 5: Exit the menu: Scroll the menu to the **"F11"** menu and press the **"MENU"** key to manually exit the menu. Or if there is no key operation for 5 seconds, it will automatically exit the menu.

4.3. Parameter setting instruction

After the control board is powered on, the LED screen displays **<Run>**

System menu description:

1. **"F01"**

Set the passage time of the gate. If no one passes within the set time, the gate will automatically close. (Default is 5 seconds)

2. **"F02"**

Gate constant opening function and whether to count when in constant opening mode.

0: Constant opening function is off.

1: When in constant opening mode, only count the number of people passing on the left.

2 or 3: When in constant opening mode, count the number of people passing on both the left and right sides. (Default is 3, counting on both sides in constant opening mode)

3. **"F03"**

Gate working mode. **0:** Free passage (not commonly used. If you want free passage, it's usually more convenient to directly bind the electromagnet without powering on) **1:** Power-off arms drop down (Default is 1, power-off arms drop down)

4. **"F04"**

Memory function. **0:** Turn off the memory function. **1:** Turn on the memory function.

After turning on the memory function, multiple cards can be swiped at once to allow multiple people to pass.

After turning off the memory function, swiped multiple cards only the last swipe card is valid, allowing only one person to pass. (Default is 0, turn off the memory function)

5. "F05"

Repeated gate opening and closing test, mainly used to test the stability and aging of the gate control board. In the test mode, press the **MENU** key to exit the test.

6. "F06"

Zero signal setting. (Default is 0, recommended to change to 1)

0: Immediately close the gate when the Zero signal is detected (used on the old tripod turnstile movement)

1: The zero signal is detected, wait for the zero signal to disappear before closing the gate. (New tripod turnstile, full-height turnstile movement, recommended to set it to 1, in case the passage speed is slow and may be stuck)

7. "F07"

Constant opening setting for the gate, in seconds. (Default is 0, turn off the constant opening function)

For example, if the constant opening is set to 3 seconds, when the gate opening signal is continuous and lasts for more than 3 seconds, the gate will remain open, allowing continuous passage until the continuous opening signal is disconnected, and then the gate will close.

8. "F08"

Gate opening delay, in seconds. (Default is 1, delay of 1 second)

This parameter is effective only when the memory function is enabled. After the memory function is turned on, during continuous passage of multiple people, there will be a pause of 1 second before the gate opens again. This function prevents the gate from opening while the previous person has not passed through the passage.

9. "F09"

Limit switch count setting. (Default is 1)

Set a limit signal to be detected several times during the opening process before closing the gate, in most cases it is set to 1.

For example, if set to 3, one gate opening signal can allow passage for 3 people in a row.

10. "F10"

Reset. After the display screen shows the letters "SYS", press the **MENU** key again to confirm and apply the reset.

11. "F11"

Exit the menu. Or automatically exit if there is no key operation within 5 seconds.

5. Product Maintenance

5.1 Daily maintenance

- To avoid the risk of electric shock, always ensure the power off before inspecting.
- Suggest inspected at regular time, to ensure all parts in good working.
- The material made by stainless steel, do not use hard material to clean it.
- Fingerprints or stubborn stains cleaning way: scrub by soap water or alcohol, sponge rinse with clean water, wipe dry as necessary.

5.2 Tips and troubleshooting

A. Tripod turnstile stay closed after swipe card

- a) check if the main board receive the open signal
- b) check if the opening signal wire loose or not, also Solenoid valve
- c) Use a multi meter to measure whether there is 24V voltage output at the solenoid valve terminal of the main board, and judge whether the solenoid valve is damaged

B. Tripod turnstile arms won't fall down when power off

- a) check if the electromagnet pole drop support is loose, readjust and fix it

C. When connected to power supply, lift the arm manually, the arm cannot lift

- a) Check if the pole drops support of the electromagnet is loose, test whether the electromagnet is magnetic with a metal object;
- b) Use a multimeter to measure whether there is 24V voltage output at the electromagnet terminal of the main board, and judge whether the main board has normal voltage output;

D. The main board is not energized after power on

- a) Use a multimeter to check whether there is 24V voltage input at the input port;
- b) Check whether the fuse is burnt out;
- c) Check whether there is 24V voltage output at the output end and judge whether the power supply is damaged;

6. Customer Service

We are very happy to help you in the future when you encounter problems or product defects, if the use or operation is not clear, please timely contact the after-sales service staff.