



## **BO-DZ403**

### **Glass Turnstile Gate**

BO-DZ403 turnstile gate with 3 sections glass panels, motor that can operate in bi-directional. It specially designed for stylish places such as office building, fitness centers etc.

In case of emergency, turnstile gate will open automatically to allow free passage when power off.

## Features

- Two way or one way working.
- 120° separation glass panels
- High quality and long service life.
- 304 brushed stainless steel, durable and antirust.
- The movement with motor structure, making the product operate very quietly.
- Support integrated with any type of access control systems.
- Anti-tailing function: only one person passes at one time.
- Indoor/outdoor use.(Shelter)
- Fire safety requirements, arms open automatically.
- Easy to install and maintain.
- 3 years warranty support.

## Customized Service

- Material optional.
- Appearance color can be customized based on installation environment.
- Dimensions can be customized to meet your request.
- Logo can be customized.
- Picture: high resolution and scene picture can be customized

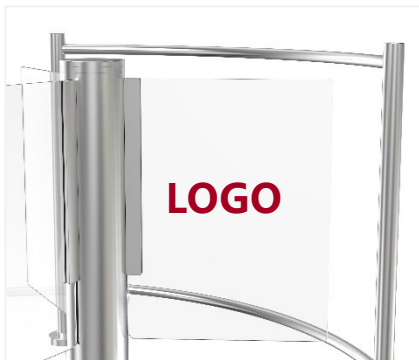

Logo Custom



Fire Safety Requirements,  
Arms Open Automatically



120° Separation Glass Panels



Steel Guardrail Protection



Anti-tailing Function: one person can pass at one time

## Access Control System

All turnstile gates can be well integrated with any 3<sup>rd</sup> party access control systems



Remote Control



Touchless Button



Card



QR Code



Fingerprint



Face



Palm Vein



**BO-DZ403 install at building**

## Specifications

|                       |                                     |
|-----------------------|-------------------------------------|
| Model No.             | BO-DZ403                            |
| Type                  | Glass Turnstile Gate                |
| Communication         | Dry contact, Relay signal, RS485    |
| Framework Material    | 304 Stainless Steel                 |
| Dimension             | 1406 * 1370 * 1050mm                |
| Net Weight            | 80kg/pcs                            |
| Arm Support           | 120° rotors with 3 sections         |
| Passage Width         | 1lane, 560mm/lane                   |
| Passing Direction     | Single directional / Bi-directional |
| MCBF                  | 15 million                          |
| Power Supply          | AC220V/110V, 50/60Hz                |
| Operation Voltage     | 24V DC                              |
| Power Consumption     | 40W                                 |
| Operation Temperature | -15 °C - 60 °C                      |
| Operation Humidity    | 0 ~ 95% (No freeze)                 |
| Working Environment   | Indoor / Outdoor(Shelter)           |
| Flow Rate             | 30 people per minute                |
| Emergency             | Arms will open automatically        |
| Flexibility           | Integrate with any access control   |



## Dimensions

Front View

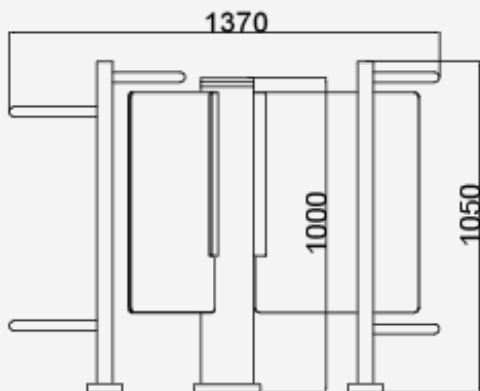

Side View

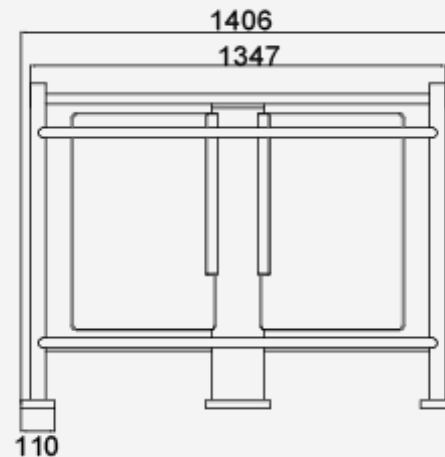

Top View

