

Thermostat

Heater With Fan With Digital Controller

DS-CS3B-KF

DS-CS3B-KF is a professional semiconductor PTC heater. Efficient heating, dynamic temperature rise. Used with a thermostat, automatic start and stop heating, higher safety. It's made of high-quality aluminum alloy, which is heat resistant and corrosion resistant.

Features

- Heating to set top temperature in 3 minutes.
- With anti-scalding protective cover, constant surface temperature.
- High thermal efficiency, long life, and high safety factor.
- Integrated multi-power mode, universal AC and DC 220VAC/24VDC optional.
- Used in the turnstile cabinet in cold weather.



Axial Fan Optional

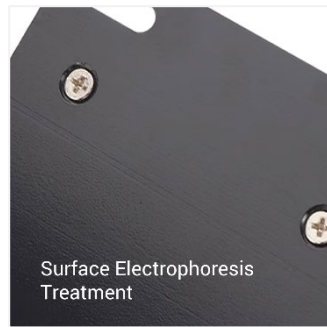

Corrosion Resistance Function



High-temperature Function



Accelerate Heat Dissipation

DS-CS3B-KF with skiing turnstile at the ski



Product Specifications

Model No.	DS-CS3B-KF		
Auxiliary Cooling Fan	Yes		
Heating Power ($\pm 20\%$)	Usage 1	150W	
	Usage 2	200W	
Working Voltage	220~240VAC 50/60Hz		
Weight	0.78kg		

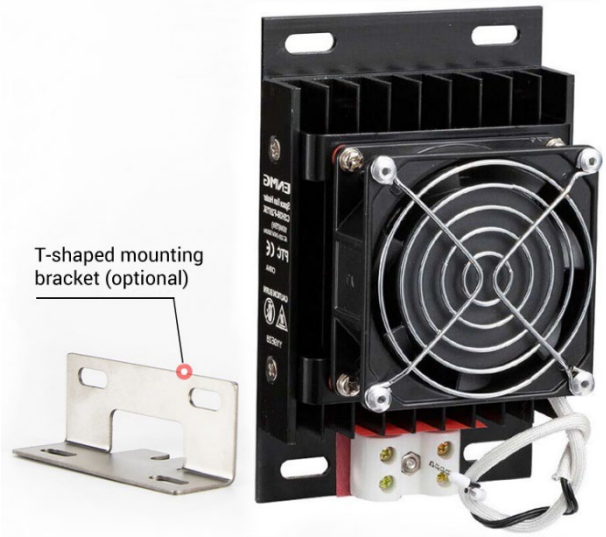

Dimensions

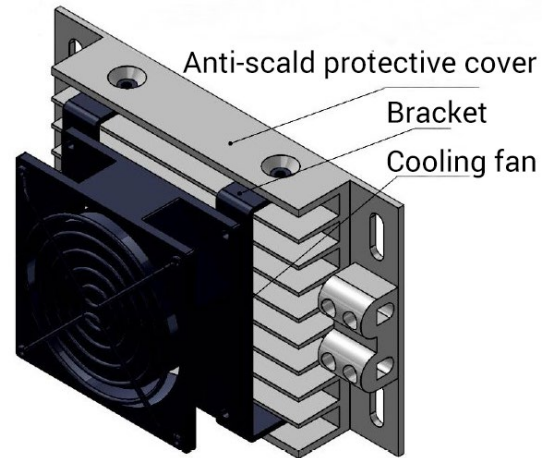
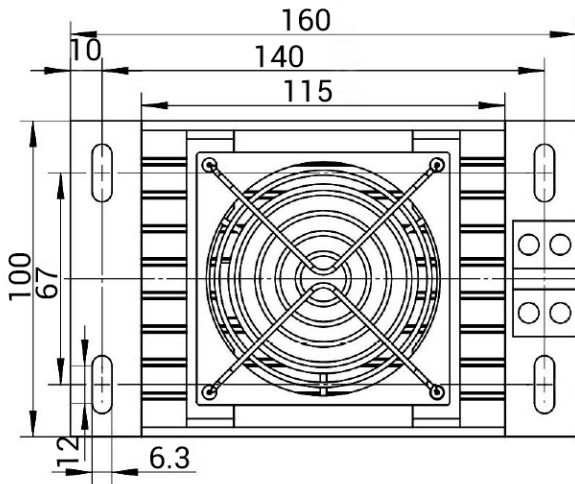
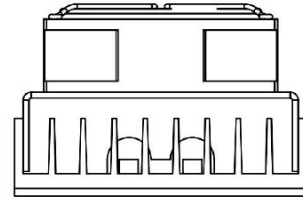
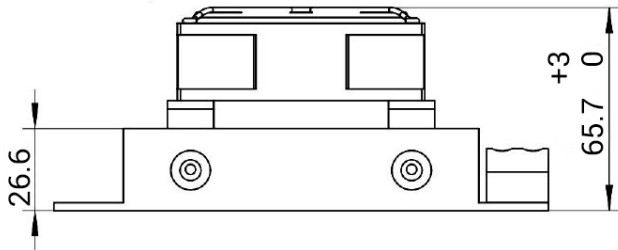

Wiring Diagram

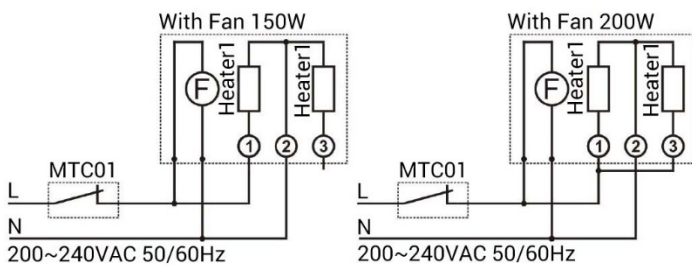

220V 150W/200W

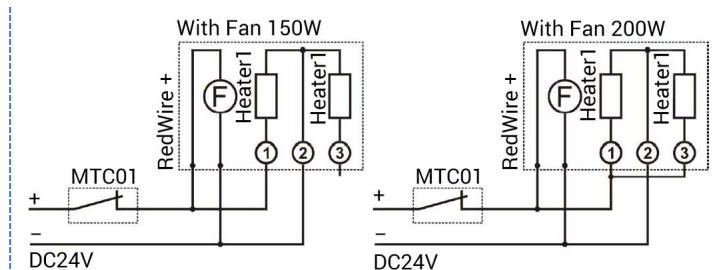

12/24V 150W/200W